



HECO-WB Threaded rod

Product information

- Lateral tensile reinforcement without glueing
- Time saving of up to 50 %
- No glueing authorisation requested
- Without temperature requirements
- Easy and reliable calculation
- High tensile strength of 800N/mm²
- Easy storage
- Insertion sleeve for countersinking
- Diameters [mm]: 16.0, 20.0
- Length [mm]: 3000, individually cut to length
- Approved and monitored product (CE-marking)



Simple solution for lateral tensile reinforcements

Headless threaded rod

Surface bright zinc plated, steel, hardened

Thread geometry
DIN 7998



Type:	HECO-WB threaded rod		
Recess:	setting tool*		
Thread:	full thread		
Material:	carbon steel		
Surface:	bright zinc plated, A2K	CHROME (VI) FREE +	Color code HECO-label

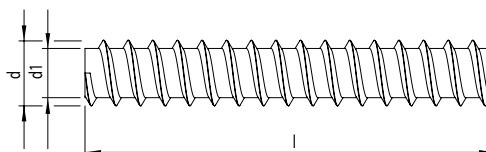

Size d x l [mm]	Thread length lg [mm]	Head diameter dk [mm]	Recess	ETA	Article No.	Pieces per package	Packaging type	Pieces per outer carton
16,0	3.000	3.000	-	-	53353	5	Industrial boxes	-
20,0	3.000	3.000	-	-	53354	5	Industrial boxes	-

* For the corresponding setting tools please see page 154

Application examples

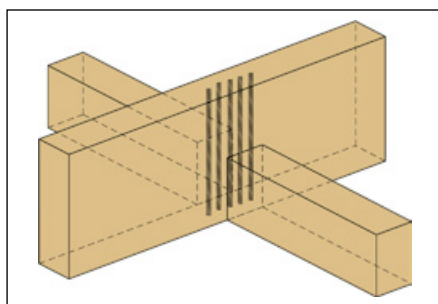

Transverse joints

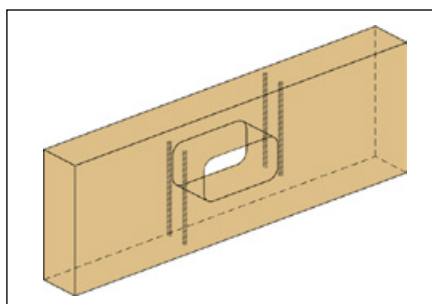

Penetrations

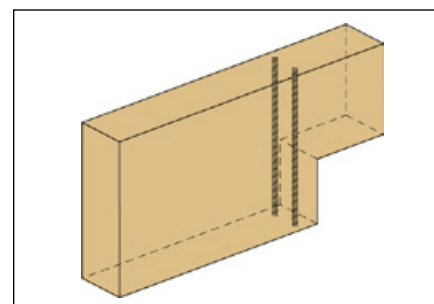

Notching

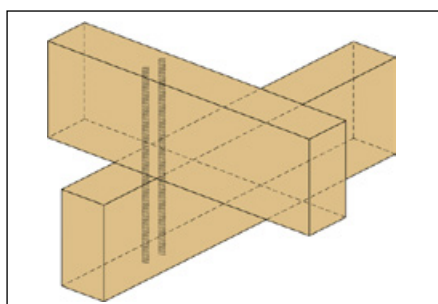

Connections

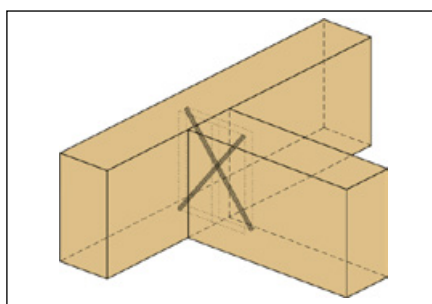

Main/secondary beams

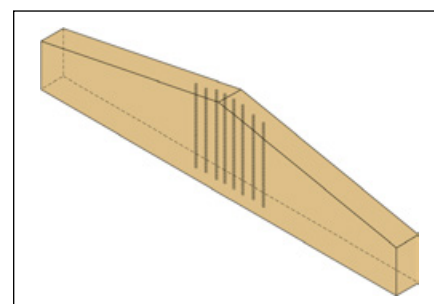

Double-pitch roof purlin